



MVH-10A							
Part No.	hp	kW	Outlet	Phase	Voltage	Amps	Max Solid
MVH-10A	0.7	0.5	25mm	1	220-240	3.4	2mm

**DESCRIPTION** The Trevoli MVH-10A is a submersible high head pump designed for drip line applications, water transfer or domestic household use with an automatic controller. Fitted with PPO impellers, diffusers and comes with a built-in stainless- steel strainer.

**FE ATURES**

- 10 metre Cable
- Includes Float Switch
- Stainless Steel upper body
- Heavy Duty plastic bottom body and handle
- Double mechanical seal (Carbon ceramic) in oil bath
- In built s/steel Strainer
- High Quality PPO stages and impellers
- S/steel Shaft
- Built in thermal overload protection

**TECHNICAL FEATURES**

- IP68
- 50 Hz
- Capacitor: 18uF
- Insulation Class: B
- Liquid Temperature: 0-35°C
- Maximum Temperature: 40°C

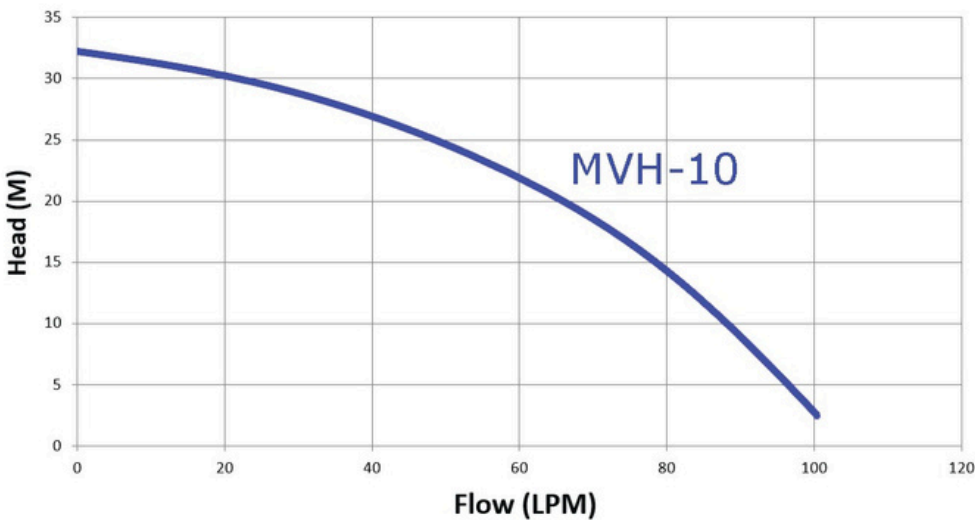
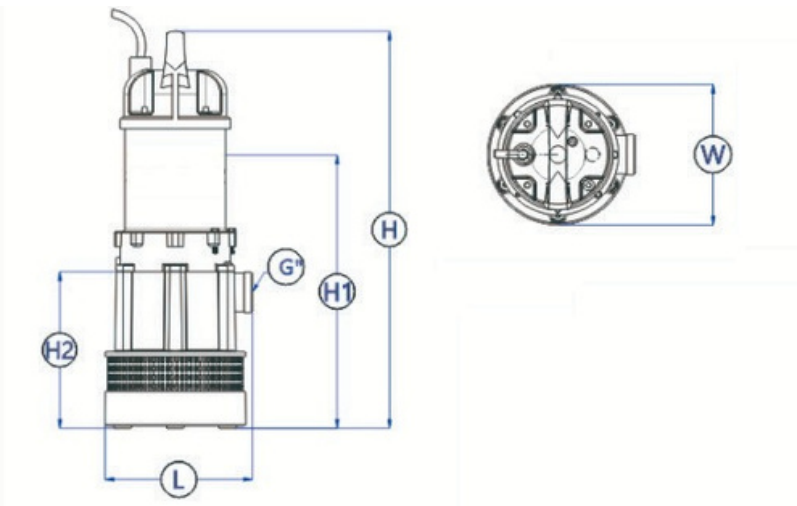

Dimensions					
Part No.	L	W	H	H1	Weight
MVH-10A	171mm	163mm	460mm	316mm	12kg